

# INSTRUCTION MANUAL

**medicare<sup>+</sup>**

## V1 COMPRESSOR NEBULISER

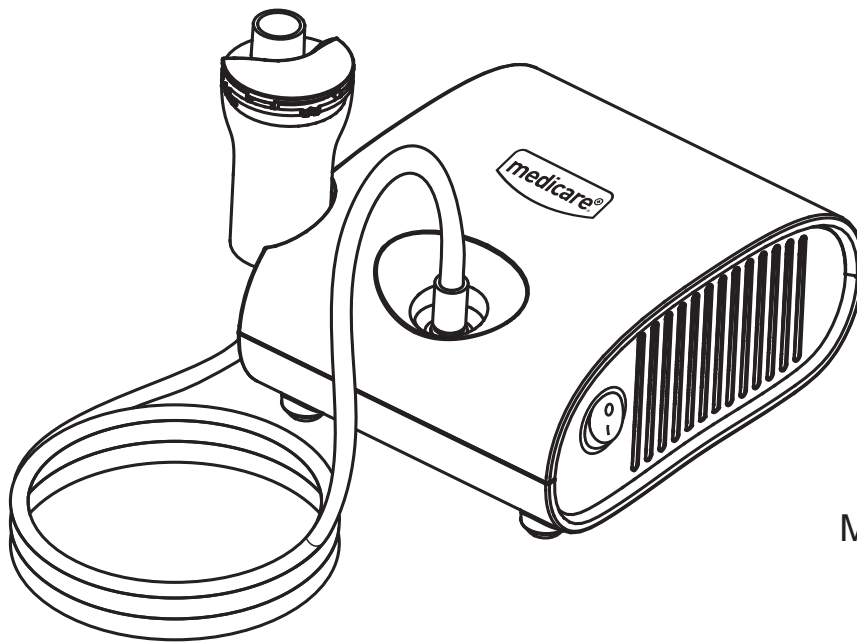

V1.7.160326

Model MD2006

Thank you very much for purchasing the Medicare V1 Compressor Nebuliser. Be sure to read this Instruction Manual before using the unit in order to use it safely and correctly.

This unit is a medical instrument. Be sure to follow the instructions of a doctor and use the unit correctly. For the type, dose and regimen of medication, be sure to follow the instructions of a doctor.

The nebulisation characteristics of this unit differ by the properties of medication. Especially with the use of a medication having high surface activity or viscosity such as medication solubilising agent or expectorant, the nebulisation rate may be reduced. The nebulisation rate may also be reduced when the temperature of medication is low.

# Table of Contents

1 . Getting to Know Your Nebuliser	
1.1 . Intended Use & Indications for Use.....	3
1.2 . Specification.....	3
1.3 . Contraindications and Adverse reaction.....	3
1.4 . Patient Populations.....	3
2 . Warnings and Cautions	
2.1 . Warnings and Cautions.....	4
3 . Maintenance	
3.1 . Precautions for Cleaning.....	7
3.2 . Maintenance.....	7
3.3 . Protect the Nature Environment.....	7
4 . Components / Accessories.....	7
5 . Operation Procedure	
5.1 . Prepare the Power Source.....	8
5.2 . Fill in the Medication.....	9
5.3 . Assemble the inhalation accessories.....	9
5.4 . Assemble the Air Tube.....	10
6 . Cleaning and disinfection	
6.1 . Clean the Unit after Inhalation.....	12
6.2 . Disinfection.....	13
6.3 . Clear the Air Filter.....	14
7 . Troubleshooting problems.....	14
8 . Symbol Form.....	16
9 . Guidance and Manufacturer's Declaration.....	17
10. Warranty Card.....	20

# 1 .Getting to Know Your Nebuliser

## 1.1. Intended Use & Indications for Use

The Medicare V1 Compressor Nebuliser MD2006 is intended to aerosolise physician-prescribed solutions for inhalation that are approved for nebulisation. The device may be used for child and adult patients in the home, hospital and sub-acute care settings, they are not intended for life support nor do they provide any patient monitoring capabilities.

## 1.2. Specification

Product Name	Medicare V1 Compressor Nebuliser
Model	MD2006
Power source	AC 230V, 60Hz
Working Environment	Temperature: 10 to 40 °C Humidity: 30 to 85% RH Atmospheric Pressure: 700 – 1060hPa
Storage Environment	Temperature: -20 to 50 °C Humidity: 30 to 85% RH Atmospheric Pressure: 700 – 1060hPa
Mode of operation	Duty Circle:20minutes ON, 40minutes OFF
Power consumption	Approximately 150VA
Sound Level	≤65dB
Capacity of Medicine Cup	≤8 ml
Nebulisation Rate	≥0.25 ml / min
Particle Size	MMAD: approximately 5 µm
Dimensions	188mm(L) x 148mm(W) x 87mm(H)
Weight	Approximately 1.35Kg (not including Medicine Cup and Air Tube)
Pollution	Degree 2
Over-voltage Category	CATEGORY II
Altitude	≤3000 m
Protection against harmful ingress of water or particulate matter	IP21
Free Flow Rate	≥5L/min
Max Pressure	200Kpa - 350Kpa

## 1.3. Contraindications and Adverse Reaction

Patients allergic to aerosolised drug.

The device should be used with caution or be used under the guidance of doctors by patients those who may show difficulty in breathing, apnoea or continuous asthma during the process of atomization.

## 1.4. Patient Populations

This device is intended for use by children or adults.

## 2 .Warnings and Cautions

### 2.1.Warnings and Cautions

#### Warning

Service or maintenance of the equipment is not permitted while used in patient.

The patient should be an intended operator who can understand the instruction brochure and the operation of the device.

When you use the unit for the first time after purchasing it or after not using it for a long period of time, be sure to clean and disinfect Medicine Cup, Inhalation Mask, Mouthpiece and Nose-piece (optional).

If the device is stored in low temperature area for long time, please operate the device after leaving the device in normal temperature for at least 2 hours.

Clean and disinfect Medicine Cup, Inhalation Mask and Mouthpiece after each use.

Be sure to dry the cleaned and disinfected parts promptly, and store them in a clean place.

Do not place or attempt to dry the device, components or any of the nebuliser parts in a microwave oven.

Keep the device out of the reach of unsupervised infants and children. The device may contain small parts that can be swallowed.

Do not wash the Main Unit and Power Plug with water or hot water.

Do not immerse the Main Unit in water or other liquid.

Do not cover the compressor with a blanket, towel or any other type of cover during use. This could result in the compressor overheating or malfunctioning.

Do not touch the device for long time during the operation of the device considering the potential overheating hurt.

Do not use the device where the device may be exposed to flammable gas or vapours.

Pentamidine is not an approved medication for use with this device.

Always dispose of any remaining medication in the medication cup in the sewer after each use.

Do not leave the device or its parts where it will be exposed to extreme temperatures or changes in humidity, such as leaving the device in a vehicle during warm or hot months, or where it will be exposed to direct sunlight.

Do not use or store the device where it may be exposed to noxious fumes or volatile substances.

Make sure that the Medicine Cup is clean before use.

Do not use in anaesthetic or ventilator breathing circuits.

#### Risk of Electrical Shock:

Do not use the compressor (main unit) or Power Plug while they are wet.

Do not plug or unplug the Power Plug into the electrical outlet with wet hands.

Do not use or store the device in humid locations, such as a bathroom. Use the device within the operating temperature and humidity.

Do not operate the device with a damaged power cord or plug. The device has to be repaired by trained professionals if the power cord is damaged.

#### Maintenance and Storage

Do not leave the cleaning solution in the nebuliser parts. Rinse the nebuliser parts with clean hot tap water after disinfecting.

Store the device and the components in a clean, safe location.

## Caution

Do not inhale by using water in the Medicine Cup.

Do not spill water or other liquids on the compressor and Power Plug. These parts are not waterproof. If liquid spills on these parts, immediately unplug the Power Plug and wipe off the liquid with gauze or other soft absorbent material.

Do not drop or apply strong shock to the Main Unit or Medicine Cup.

Provide close supervision when this device is used by, on or near infants, children or compromised individuals.

If the device is used continuously, the service life of the device may be shortened.

Limit use to 20 minutes at a time, and allow a 40 minutes interval before using the device again.

## Caution

Do not insert any object into the compressor.

Make sure the Air Filter is clean. If the Air Filter has changed colour or has been used for more than 60 days, replace it with a new one.

Make sure the Medicine Cup is correctly assembled, the Air Filter is properly installed, and the Air Tube is correctly connected to the compressor and the Medicine Cup. Air may leak from the Air Tube during use if not securely connected.

Do not use the device if the Air Tube is bent.

Do not add more than 8ml of medication to the Medicine Cup.

Do not operate the device at temperatures greater than +40°C (+104°F).

Do not tilt the Medicine Cup so the angle of the kit is greater than 45°. Medication may flow into the mouth.

Use only Medicare authorized parts and accessories. Parts and accessories not approved for use with the device do not perform the expected specification or it may damage the unit.

Changes or modification not approved by Fleming Medical will void the user warranty.

To avoid injury to the nose mucosa, do not squeeze the optional Nosepiece into the back of the nose.

When using this device, there will be some noise and vibration caused by the pump in the compressor. There will also be some noise caused by the emission of compressed air from the Medicine Cup. This is normal and does not indicate a malfunction.

Do not use the device while sleeping or if drowsy.

Remove the Power Plug from the device after use.

Unplug the Power Plug from the electrical outlet before cleaning the device.

Do not store the Air Tube with moisture or medication remaining in the Air Tube. This could result in infection as a result of bacteria.

The handle of the device will be a little hot after continuous operation, please wait 5 minutes to touch it.

# 3 .Maintenance

## 3.1 . Precautions for Cleaning

Clean the casing of the main unit by using a soft cloth moistened with water or mild detergent. Do not use abrasive cleaners.

## 3.2 . Maintenance

This product is generally recommended that it be inspected every two years to ensure proper function and performance.

## 3.3 . Protect the Nature Environment

Please help to protect natural environment by respecting national and/or local recycling regulations at the end of their useful life.

# 4 .Components / Accessories

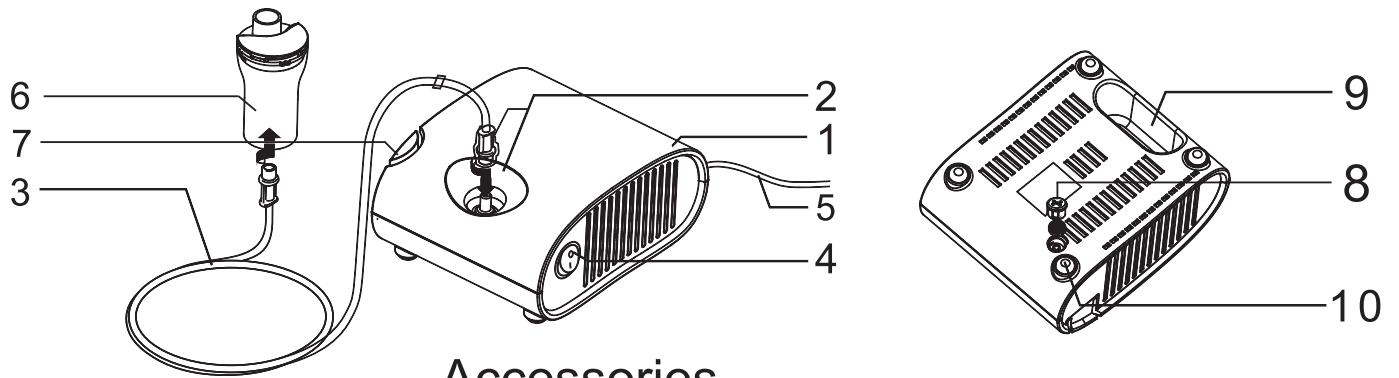

## Accessories

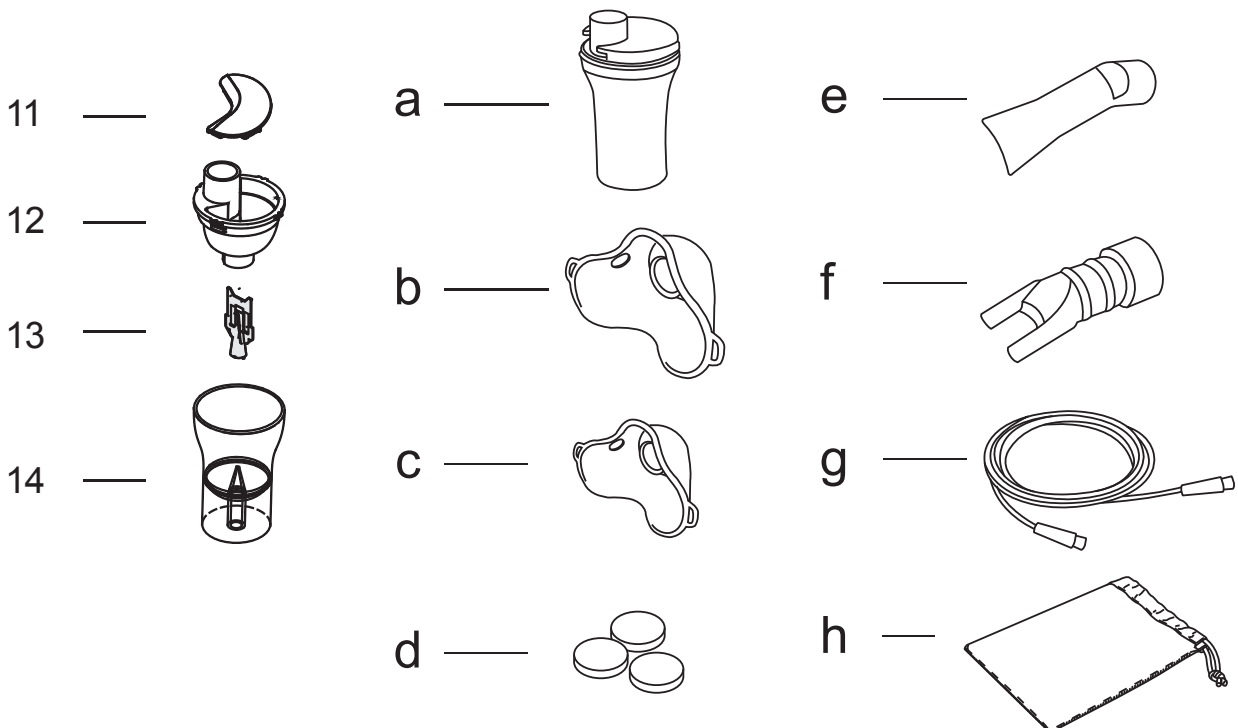

## Name of each components

- |                         |                              |
|-------------------------|------------------------------|
| 1 Compressor(Main Unit) | 9 Handle                     |
| 2 Air outlet            | 10 Footpad                   |
| 3 Air Tube              | 11 Medicine Cup Cover        |
| 4 Power Switch          | 12 Medicine Cup Upper Shell  |
| 5 Power Line            | 13 Nebuliser Slice           |
| 6 Medicine Cup          | 14 Medicine Cup Bottom Shell |
| 7 Medicine Cup Holder   |                              |
| 8 Air Filter Cover      |                              |

## Name of Accessories:

- |                          |                |
|--------------------------|----------------|
| a. Medicine Cup          | e. Mouthpiece  |
| b. Adult Inhalation Mask | f. Nosepiece   |
| c. Child Inhalation Mask | g. Air Tube    |
| d. Air Filters (x10)     | h. Storage Bag |

## 5 .Operation Procedure

---

### 5.1. Prepare the Power Source

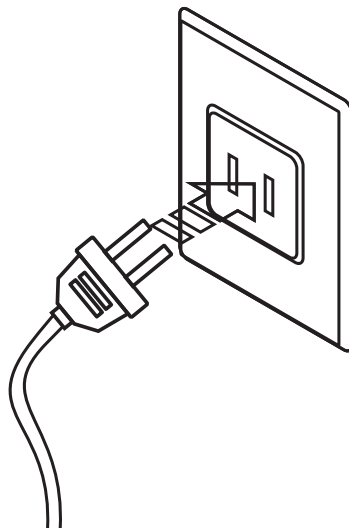

## 5.2. Fill in the Medication

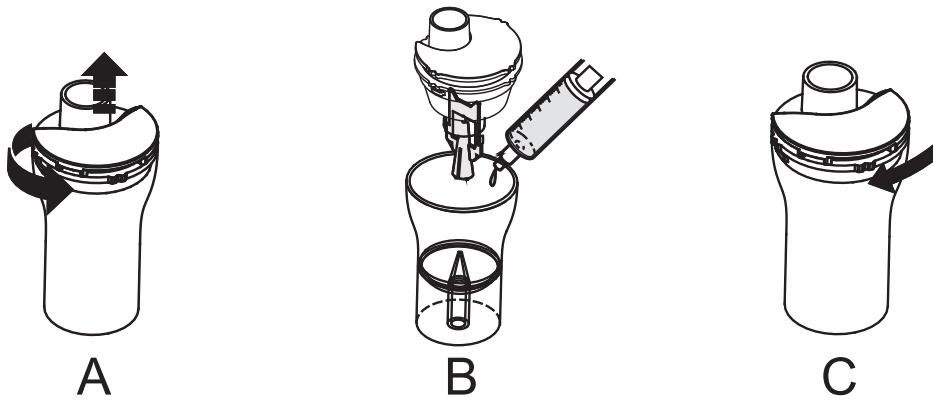

Step 1: Lift up the Mouthpiece or Nosepiece Mask from the Medicine Cup.

Step 2: Unscrew the Medicine Cup Upper Shell as shown in the picture A.

Step 3: Fill in the correct amount of prescribed medication in the Medicine Cup Bottom Shell as the shown in the picture B.

Step 4: Screw the Medicine Cup Upper Shell to the Medicine Cup Bottom Shell clockwise until securely closed as the shown in the picture C.

## 5.3. Assemble the inhalation accessories

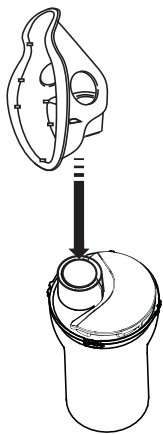

Assemble the Mask

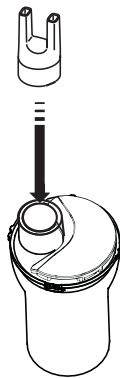

Assemble the Nosepiece  
(optional)

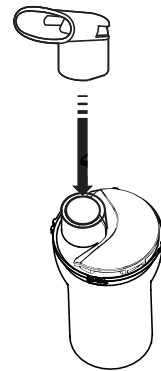

Assemble the Mouthpiece

## 5.4. Assemble the Air Tube

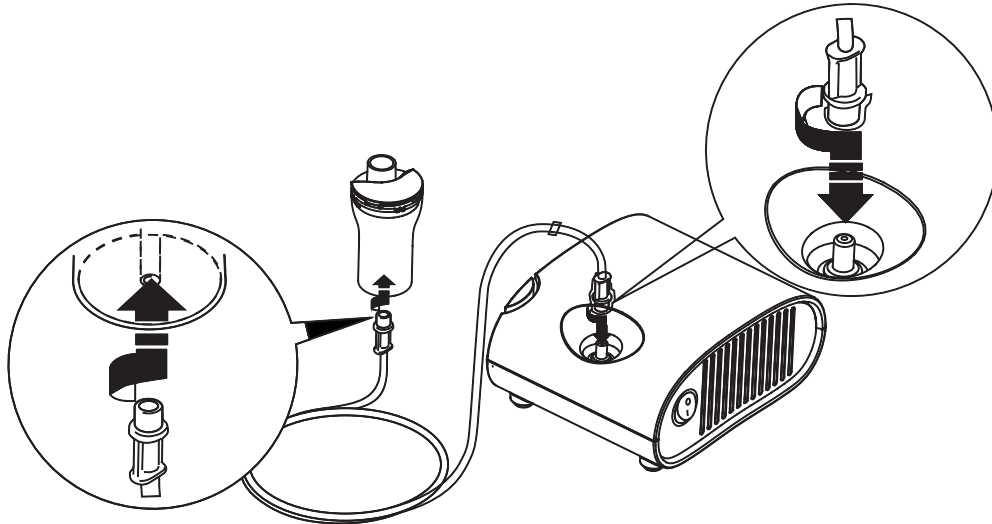

Step 1: Twist the Air Tube plug and push it firmly into the Air Tube Connector on the upper side of the compressor.

Step 2: Twist the Air Tube plug slightly and push it firmly into the Air Tube connector on the bottom of the Medicine Cup.

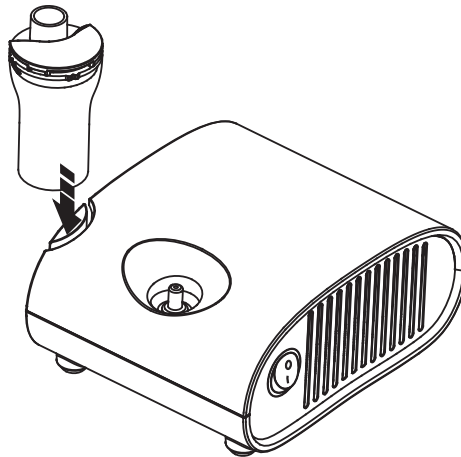

Step 3: Use the Medicine Cup Holder as a temporary holder for the Medicine Cup.

## 5.5. How to Use the Unit

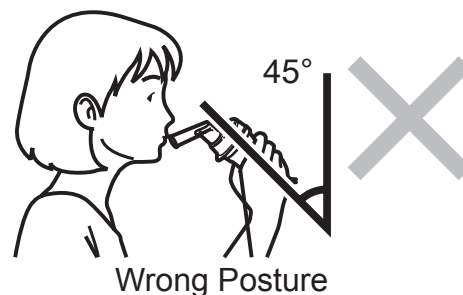

Step 1: Hold the Medicine Cup as shown in the Figure above.

Note: Do not tilt the Medicine Cup greater than 45°. Otherwise medication may flow into the mouth.

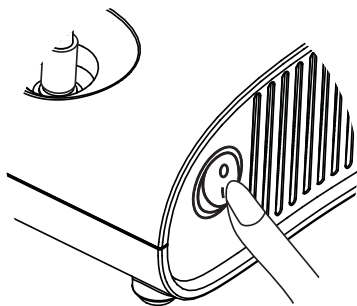

Step 2: Turn on the Unit: Turn the Power Switch to the ON ( I ) position. As the compressor starts, nebulisation begins. (To stop nebulisation, turn the power switch to the OFF ( O ) position.)

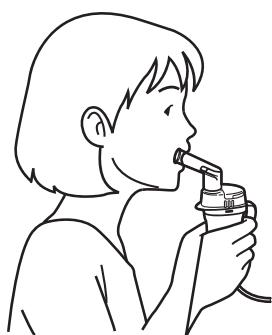

**Mouthpiece**



**Mask**



**Nosepiece**

Step 3: Inhale medication as instructed by physician, difference between the inhalation accessories are shown as above.

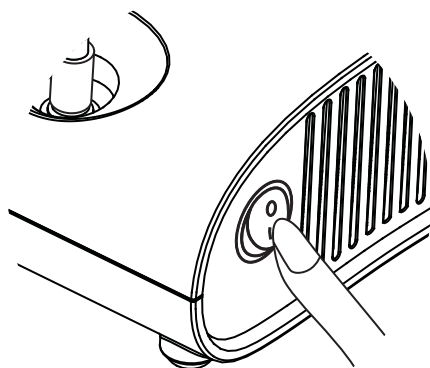

Step 4: Turn off the Unit: Turn the Power Switch to the OFF ( O ) position. As the compressor stops, nebulisation stops.

Step 5: Disconnect the Air Tube from the Medicine Cup.

Hold the Air Tube Plug and gently pull it down .Check the Air tube. No condensation or moisture should remain in the Air Tube.

Note:

If any condensation or moisture remains in the Air tube, remove the moisture from the air tube. Follow the directions below:

- 1. Make sure the Air Tube is still connected to the air tube connector on the upper side of the compressor.
- 2. Turn on the Unit, and the compressor will start and pump air through the air tube to expel the moisture.
- 3. Turn off the Unit.

Step 6: Disconnect the air tube from the compressor

Step 7: Unplug the Power Plug

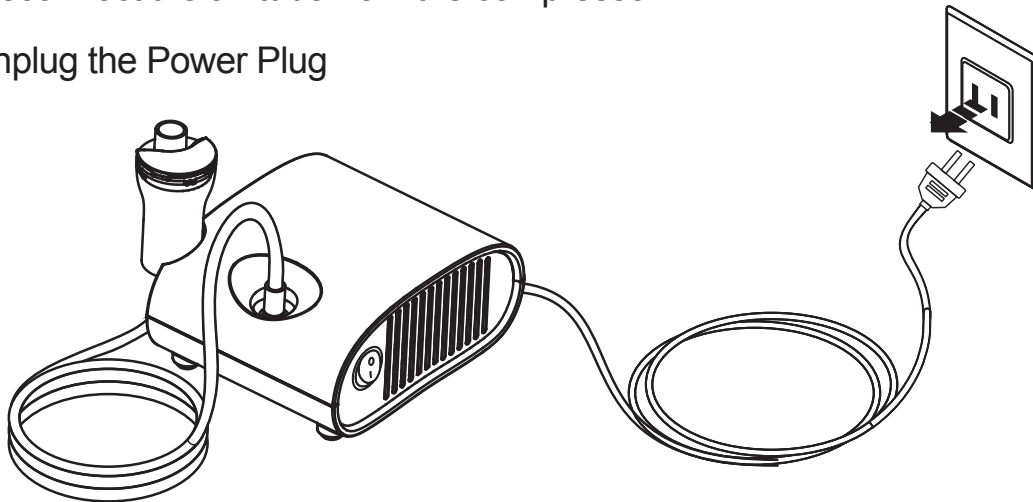

## 6 .Cleaning and Disinfection

---

### 6.1. Clean the Unit after Inhalation

Step 1: Remove the inhalation accessory from the Medicine Cup.

Step 2: Disconnect the Air Tube from the Medicine Cup.

Step 3: Gently screw off the Medicine Cup Upper Shell.

Step 4: Discard the remaining medication.

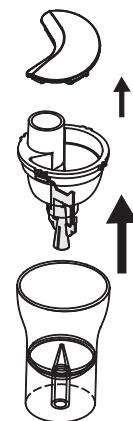

Step 5: Wash the parts sufficiently in water.

Step 6: Hand dry or air dry in a clean environment using a soft, clean, lint-free cloth.

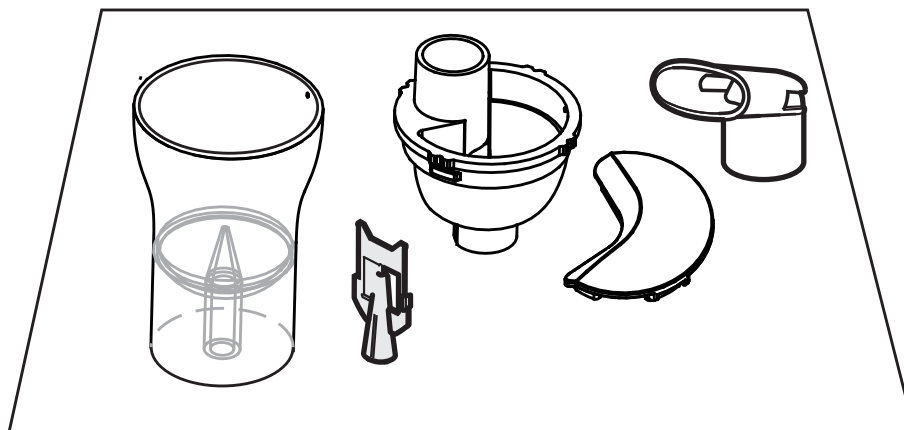

Step 7: Assemble the Medicine Cup and store it in a dry bag.

## 6.2. Disinfection

Disinfect the Medicine Cup and Mouthpiece, Masks or nosepiece after the last treatment of the day as following:

Use a commercially available medical alcohol disinfectant with the instructions provided by the disinfectant manufacturer(Recommended contact time less than 10 seconds):

Step 1: Submerge the parts in the disinfectant solution for the specified period.

Step 2: Remove the parts and discard the solution.

Step 3: Rinse the parts with clean Drinking Water, shake off excess water and allow to air dry in a clean environment.

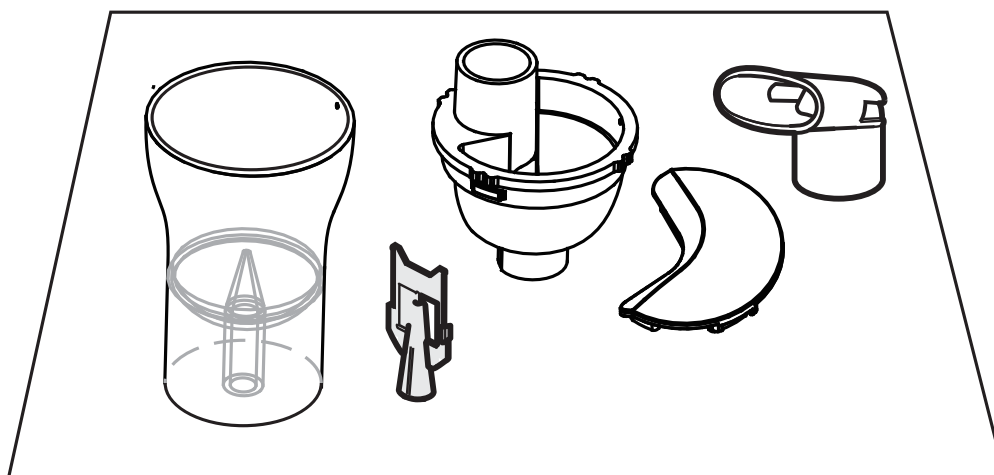

## 6.3. Clear the Air Filter

Step 1: Pull the Air Filter cover to remove from the back side of the compressor.

Step 2: Remove the dirty Air Filter.

Step 3: Insert a new Air Filter.

Step 4: Put the Air Filter cover back to the compressor.

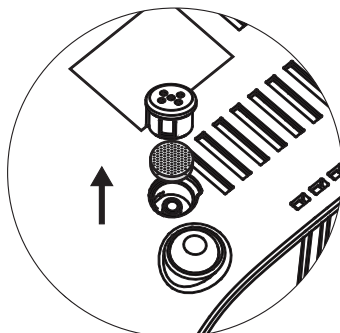

Note:

- If the Air Filter has changed colour or has been used for more than 60 days, replace it with a new one.

## 7 .Troubleshooting Problems

Trouble	Possible Cause	How to Correct
No power to the device when the Power Switch is on.	The AC adapter is not plugged into an electrical outlet.	Turn the Power Switch off. Plug the AC adapter into an electrical outlet. Turn the device on.
No nebulisation or low nebulisation rate when the power is on.	No medication in the Medicine Cup. Too much or too little medication in the Medicine Cup.	Add the correct amount of prescribed medication to the Medicine Cup.
	The Baffler is not attached to the Medicine Cup Upper Shell or incorrectly positioned.	Make sure the Baffler is correctly attached to the Medicine Cup Upper Shell.
	The Medicine Cup is not correctly assembled.	Make sure the Medicine Cup is correctly assembled and the inhalation accessory is correctly attached.

## 7 .Troubleshooting Problems













Trouble	Possible Cause	How to Correct
No nebulisation or low nebulisation rate when the power is on.	The nozzle is blocked.	Clean and disinfect the Nebuliser Kit to remove the blockage
	The Medicine Cup is tilted at an incorrect angle.	Hold the Medicine Cup correctly. Do not tilt the Medicine Cup so the angle of the kit is greater than 45 degrees.
	The Air Tube is incorrectly attached.	Make sure the Air Tube is correctly attached to the compressor and the Medicine Cup.
	The Air Tube is folded or damaged. The Air Tube is blocked.	Make sure the Air Tube is not folded, kinked or bent. Inspect the Air Tube for any damage. Replace the Air Tube if damaged.
	The Air Filter is dirty	Replace the Air Filter with a new clean Air Filter.
The device is very hot.	The compressor is covered.	Do not cover the compressor with any type of cover during use.
	Operating continuously over 20 minutes.	Limit use to 20 minutes at a time and allow a 40 minutes interval before using the device again.
The device is abnormally loud.	The Air Filter cover is incorrectly attached.	Attach the Air Filter cover correctly. Make sure the Air Filter cover is not blocked.

### Note:

If any operator requests more information such as circuit diagrams, parts list and product descriptions, for repairs carried out by qualified technical personnel, please contact us.

If the unit does not nebulise normally after taking the above-mentioned procedure, contact the store where you purchased the unit or the nearest Medicare dealer.

## 8 .Symbol Form

Symbol	Explanation
<b>IP21</b>	Protection against ingress of dust and water, it means the device could protected against dust with $\phi \geq 12.5\text{mm}$ and vertical falling water drop°.
	Manufacturer
	Indicates the date when the medical device was manufactured.
	This symbol indicates that the device includes IEC 60601-1 Type BF Applied Part.
	The symbol indicates that the device should be sent to the special agencies according to local regulations for separate collection after its useful life.
	Symbol for "THE OPERATION GUIDE MUST BE READ"; Indicates the need for the user to consult the instructions for use.
	This symbol shall be accompanied by the manufacturer's serial number.
	Indicates the Authorised representative in the European Community.
	Symbol for CE Mark. This symbol certifies that a product has met European Union consumer safety, health or environmental requirements.
	Symbol for "Class II Equipment".
	The Green Dot is the license symbol of a European network of industry-funded systems for recycling the packaging materials of Symbol for "Class II Equipment" consumer goods.
	Symbol for "Medical Device".
	Symbol for "Unique Device Identification".

## 9 .Guidance and Manufacturer’s Declaration

- 1) This equipment needs to be installed and put into service in accordance with the information provided in the ACCOMPANYING DOCUMENTS;
- 2) IMMUNITY TEST LEVELS for basic safety and essential performance of ME equipment and ME systems should be chosen based on a high probability of maintaining basic safety and essential performance, and shall be according to the professional healthcare facility environment, home healthcare environment, and special environment, based on the locations of intended use.
- 3) HOME HEALTHCARE ENVIRONMENT is dwelling place in which a patient lives or other places where patients are present, excluding professional healthcare facility environments where operators with medical training are continually available when patients are present. Such as schools, outdoors, domiciles, vehicles hotels and pensions.
- 4) Please dispose the parts of the device once it is out of use according to local authorities.
- 5) MANUFACTURER will provide circuit diagrams, component part lists, descriptions, calibration instructions to assist to SERVICE PERSONNEL in parts repair.
- 6) Components such as power supply cord can only be replaced by professionals and are not allowed to be replaced by users themselves.
- 7) Use of this equipment adjacent to or stacked with other equipment should be avoided because it could result in improper operation. If such use is necessary, this equipment and the other equipment should be observed to verify that they are operating normally.
- 8) Use of accessories, transducers and cables other than those specified or provided by the manufacturer of this equipment could result in increased electromagnetic emissions or decreased electromagnetic immunity of this equipment and result in improper operation.
- 9) Not use with hf surgical equipment.

EXAMPLE: As indicated in Table 6 of EN 60601-1-2:2015+A1:2021: for ME EQUIPMENT, a typical cell phone with a maximum output power of 2 W yields  $d = 3.3$  m at an IMMUNITY LEVEL of 3 V/m.

### A1 Declaration-Electromagnetic Emissions

Guidance and manufacturer’s declaration-electromagnetic emission		
The Compressor Nebuliser is intended for use in the electromagnetic environment specified below. The customer or the user of the Compressor Nebuliser should assure that it is used in such an environment.		
Emission test	Compliance	Electromagnetic environment-guidance
RF emissions CISPR 11	Group 1	The Compressor Nebuliser use RF energy only for its internal function. Therefore, its RF emissions is very low and is not likely to cause any interference in nearby electronic equipment.

RF emissions CISPR 11	Class B	The Compressor Nebuliser is suitable for use in all establishments, including domestic establishments and those directly connected to the public low-voltage power supply network that supplies buildings used for domestic purposes.
Harmonic emissions IEC 61000-3-2	Class A	
Voltage fluctuations/ flicker emissions IEC 61000-3-3	Complies	

## A2 Guidance & Declaration - electromagnetic immunity

Guidance and manufacturer's declaration – electromagnetic immunity			
The Compressor Nebuliser is intended for use in the electromagnetic environment specified below. The customer or the user of the Compressor Nebuliser should assure that it is used in such an environment.			
Immunity Test	IEC 60601 Test Level	Compliance Level	Electromagnetic Environment Guidance
Electrostatic discharge (ESD) IEC 61000-4-2	±8 kV contact ±2 kV, ±4 kV, ±8 kV, ±15 kV air	±8 kV contact ±2 kV, ±4 kV, ±8 kV, ±15 kV air	Floors should be wood, concrete or ceramic tile. If floors are covered with synthetic material, the relative humidity should be at least 30 %.
Electrical fast transient/burst IEC 61000-4-4	±2 kV for power supply lines	±2 kV for power supply lines	Mains power quality should be that of a typical commercial or hospital environment.
Surge IEC 61000-4-5	± 0.5kV, ± 1 kV line to line	± 0.5kV, ± 1 kV line to line	Mains power quality should be that of a typical commercial or hospital environment.
Voltage dips, short interruptions and Voltage variations on power supply input lines IEC 61000-4-11	<5 % UT (>95% dip in UT.) for 0.5 cycle <5 % UT (>95% dip in UT) for 1 cycle 70% UT (30% dip in UT) for 25/30 cycles <5% UT (>95 % dip in UT) for 5/6 sec	<5 % UT (>95% dip in UT.) for 0.5 cycle <5 % UT (>95% dip in UT) for 1 cycle 70% UT (30% dip in UT) for 25/30 cycles <5% UT (>95 % dip in	Mains power quality should be that of a typical commercial or hospital environment. If the user of the Compressor Nebuliser require continued operation during power mains interruptions, it is recommended that the Compressor Nebuliser be powered from an uninterruptible power supply or a battery.

Power frequency (50/60 Hz) magnetic field IEC 61000-4-8	30 A/m	30 A/m	Power frequency magnetic fields should be at levels characteristic of a typical location in a typical commercial or hospital environment.
NOTE UT is the a.c. mains voltage prior to application of the test level.			

### A3.Guidance & Declaration - electromagnetic immunity concerning Conducted RF & Radiated RF

Guidance and manufacturer's declaration – electromagnetic immunity			
The Compressor Nebuliser is intended for use in the electromagnetic environment specified below. The customer or the user of the Compressor Nebuliser should assure that it is used in such an environment.			
Immunity Test	IEC 60601 Test Level	Compliance Level	Electromagnetic Environment Guidance
Conducted RF IEC 61000-4-6	3 Vrms 150 kHz to 80 MHz 6 Vrms in ISM bands and amateur radio bands	3 Vrms 150 kHz to 80 MHz 6 Vrms in ISM bands and amateur radio bands	Portable RF communications equipment (including peripherals such as antenna cables and external antennas) should be used no closer than 30 cm (12 inches) to any part of the Compressor Nebuliser, including cables specified by the manufacturer. Otherwise, degradation of the performance of this equipment could result.
Radiated RF IEC 61000-4-3	10 V/m 80 MHz to 2.7 GHz 385MHz- 5785MHz Test specifications for ENCLOSURE PORT IMMUNITY to RF wireless communication equipment (Refer to table 9 of IEC 60601-1-2:2014+A1:2020)	10 V/m 80 MHz to 2.7 GHz 385MHz-5785MHz Test specifications for ENCLOSURE PORT IMMUNITY to RF wireless communication equipment (Refer to table 9 of IEC 60601-1-2:2014+A1:2020)	



#### VAPO Healthcare Co., Ltd.

Southern unit of third floor, building B, No.99, Yudai West Rd,  
High tech district, Kunshan, Suzhou, 215301 Jiangsu, P.R. CHINA

#### Share Info GmbH

Am Schulzentrum 12,  
41564 Kaarst, GERMANY



#### FLEMING MEDICAL LTD

Limerick, V94 K6W4, IRELAND  
WWW.FLEMINGMEDICAL.IE

# 10.Warranty Card

<b>MODEL</b>		
<b>Warranty Period</b>	One year from purchasing date	
<b>Purchasing Shop</b>	Name:	Telephone:
	Address:	
<b>Customer</b>	Name:	Telephone:
	Address:	

## Requiring Record

Date	Trouble	Service Man

<b>Guarantee Regulation</b>	<ul style="list-style-type: none"> <li>▪ The Guarantee is for the Main Unit, not applicable for the Medicine Cup as the service life of the medicine cup varies greatly according to usage.</li> <li>▪ The product must be accompanied by proof of purchase, either a bill of sale or other proof supporting that the device is within warranty period.</li> <li>▪ This warranty does not apply to a product which has been damaged as a result of improper maintenance, an accident, improper voltage supply or any other form of misuse. The warranty is also void if the owner repairs or modifies the product in any way. Fleming Medical is not liable for any incidental or consequential damages with regard to this product. The warranty also excludes any liability other than what is stated above. No other warranty is given.</li> <li>▪ LEGAL RIGHTS VARY FROM COUNTRY TO COUNTRY. SOME COUNTRIES DO NOT ALLOW THE EXCLUSION OR LIMITATION OF INCIDENTAL OR CONSEQUENTIAL DAMAGES, SO THE ABOVE LIMITATION MAY NOT APPLY TO YOU.</li> </ul>
-----------------------------	---